

# Contents

Introduction.....	4	Time Exposures .....	21
Operating Controls .....	2/3/36/37	The Self Timer .....	23
Specification .....	5	Changing the Batteries .....	25
Loading the Camera .....	6	Extending the Range .....	26
Using the Camera .....	10	For close-up work ...	30
Depth of Field .....	12	Accessories.....	31
Using the Meter .....	13	Caring for your Camera .....	33
Zenith 11 Meter .....	15	Troubleshooting .....	34
Removing Exposed Film .....	17	After Sales Service	35
Photography with Flash .....	19	Owners Information/ Notes .....	38

*The illustration/description of equipment and accessories throughout this book is for information only and should by no means be considered an offer of sale.*

# Zenith 12 Operating Controls

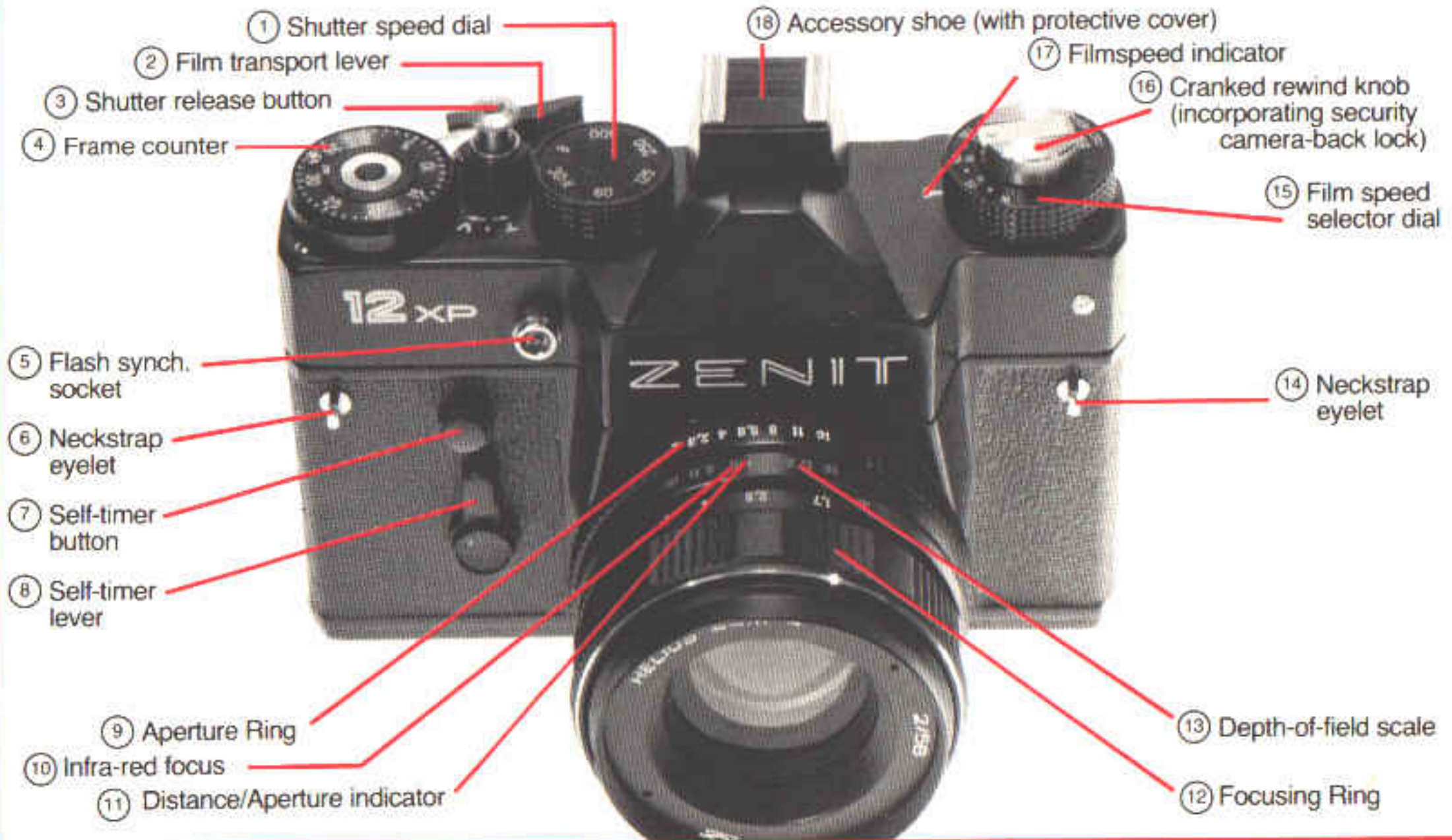

# Zenith 12 Operating Controls

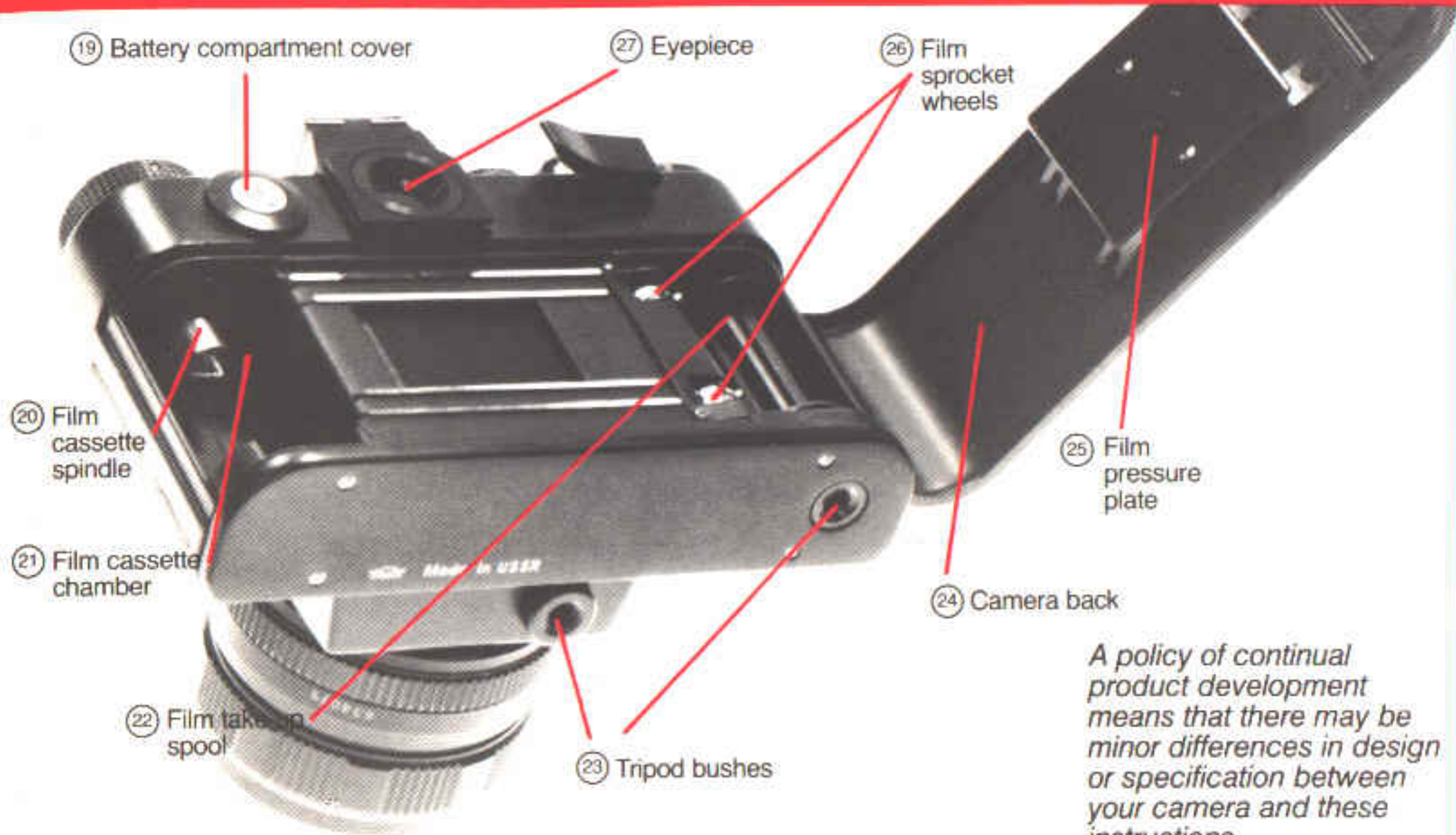

*A policy of continual product development means that there may be minor differences in design or specification between your camera and these instructions.*

To get the best results from your Zenith study these instructions thoroughly to make sure you are familiar with the essential features of the camera before you start taking pictures. It is suggested that before loading the first film you sit down with the instructions in front of you and try out all the controls to generally 'get the feel' of the camera. It is also recommended that a 'test' film be shot and the results examined before taking further pictures. This will enable any early operator errors to be corrected and will give you confidence for the future.

As a 'system' camera your Zenith will accept a

## Introduction

large number of different lenses and additional accessories; we particularly recommend as most suitable those from the **Helios** range which will enable you to cope with almost any photographic situation.

Your Zenith is sturdily built to work happily under widely varying conditions but it should always be remembered that as a precision optical instrument it must at all times be treated with due care and consideration and protected from shock, damp, dust, sand and sudden changes of temperature. With care it

will give many years of reliable service – and *brilliant* pictures.

This booklet has been provided to enable you to get the best results as quickly as possible and is not intended to be a comprehensive manual of photography. There are many good inexpensive books on photographic technique available and your dealer will be pleased to recommend one suitable for your particular need.

# Specification

<b>Format</b>	24 x 36mm; using standard 35mm cassettes of 12, 20, 24 or 36 exposure colour or black and white film.
<b>Shutter</b>	Horizontal travelling Focal Plane type, speeded 1/30, 1/60, 1/125, 1/250 and 1/500th second plus B (brief time). Linked to self-timer giving approximately 7 seconds delay.
<b>Flash Synchronisation</b>	Electronic flash at 1/30th sec. through 'Hot-shoe' or standard 3mm co-axial socket.
<b>Viewing/Focusing system</b>	Eye-level pentaprism/instant return mirror shows upright laterally correct image. Bright Fresnel focusing screen with central microprism spot.
<b>Exposure meter</b>	<i>Zenith 12.</i> Built-in CdS cell with L.E.D. indicators in the viewfinder. Power source, two Mallory D386 cells. (These should be replaced once a year.) <i>Zenith 11</i> Selenium cell with match-needle read out. Both meters calibrated for 16-500 ASA/13-28 DIN.
<b>Frame counter</b>	Additive 0-36 manual resetting type.

<b>Standard Lens</b>	<b>Construction</b>	<b>Diaphragm type</b>	<b>Aperture range</b>	<b>Distance scale</b>	<b>Filter size</b>	<b>Lens mount</b>
Helios 44M-4 58mm focal length	6 elements in 4 groups	Fully automatic instant re-open.	f/2-f/16 with click stops at full and half apertures (except between f/11 and f/16)	0.5m to Infinity	52mm screw	42mm thread accepts standard single pin automatic lenses and accessories

# Loading the Camera – Step by step instructions



Always load the camera in subdued light; if outdoors shield from direct sunlight.



Make sure that the indicator on the Shutter Release Button [3] is facing towards the front of the camera.



Depress Shutter Release Button [3] – if shutter does not fire advance Transport Lever [2] in **short strokes** until it stops and press Shutter Release Button [3] again.



Lift Rewind Knob [16] to open back.



Insert film cassette into Film Chamber [21] projection of cassette to bottom.

Push Rewind Knob [16] down turning slightly to seat into cassette.

Draw out enough film to insert tip of leader into any of Take-up Spool's

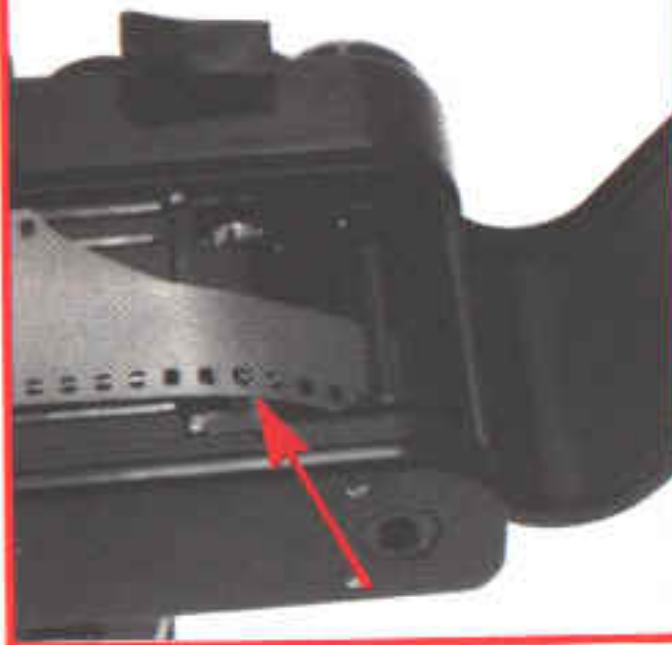

[22] slots ensuring that the second hole engages with a tooth on the spool. Ease film forward by **short strokes** of Transport Lever [2] until it stops. The lower Sprocket Teeth [26] should be properly engaged.



Fire shutter. Advance film by **short strokes** of transport lever until both top and bottom sprockets are engaged. If necessary tighten film on Take-up Spool [22] by turning the flange at the base of the spool anti-clockwise with the finger and in the cassette by gently turning the Rewind Knob [16] in the direction of

the arrow on the lever until resistance is felt. This is especially necessary with twelve exposure films.

Close the back of the camera until it clicks shut. Complete wind-on if necessary until Transport Lever [2] stops.



Fire shutter. Advance film Transport Lever [2] using short strokes until it stops. The Rewind Knob [16] should revolve whilst this is being done.





Fire shutter and advance film again. Set Frame Counter [4] to zero.



Set Film Speed Selector Dial [15] against Indicator [17] appropriate to the speed of the film to be used. There are two scales for films rated in ASA and DIN. Only click-stopped numbered or intermediate positions may be used. Intermediate positions are proportional. If using 1000 ASA film set the

selector to 500 ASA but use the next faster shutter speed than indicated by the meter **or** close the aperture ring by one full stop.

Zenith 11 owners see Page 15 for how to set exposure meter.

The camera is now ready for use.

# Using the Camera



**Set the Speed Dial [1]** appropriately according to the subject. The dial is marked in figures that represent fractions of a second—i.e. “60” is 1/60th second. It may be turned in either direction but not between “500” and “B” and must not be

left between marked speeds.

Initially we suggest that outdoors the speed set should not be less than 1/125th sec.

*continued . . .*

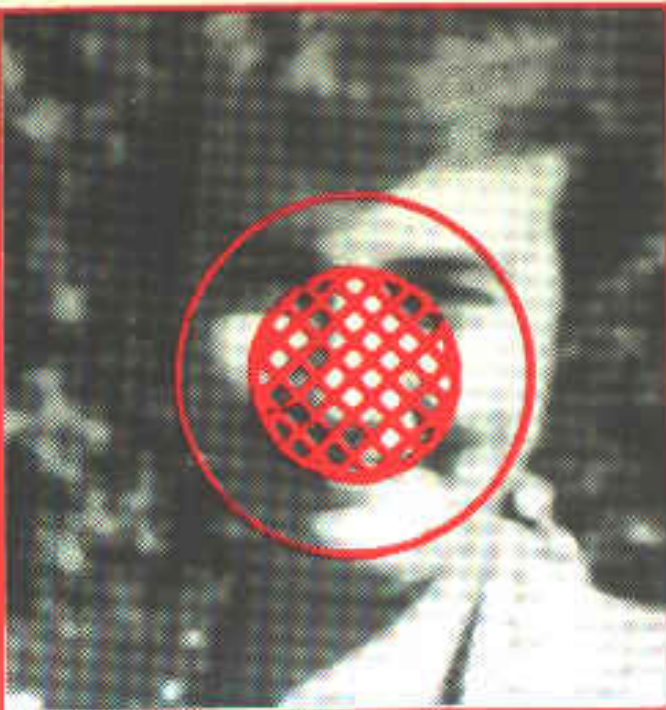

**Focusing.** Look through the Viewfinder [27] and roughly decide what you wish to take remembering you are actually looking through the lens. Focus by turning the Focusing Ring [11] clockwise for close and anti-clockwise for far distance until the subject is sharp and clear on the large viewing screen. For



critical focusing use the inner of the two rings in the centre and adjust until the image is clear and undistorted. Since you are viewing and focusing through the actual lens that takes the finished picture you can feel safe in the knowledge that there will be no parallax problems (no more cut-off heads in close-up

portraits and the like). There's a built-in safety margin of course, in common with many other modern single lens reflex cameras, the viewfinder showing an overall area somewhat smaller than the total film area. This ensures that *everything you see in the viewfinder appears* in the finished picture despite the fact that slide mounts and masks in printing equipment actually cover part of the film's image.

# Depth of Field



The lens is also provided with a scale calibrated in meters but it will seldom be necessary to refer to this.

This is the depth of field scale [13] and works as follows:—

All lenses when focused on a given subject, will show some objects in front of and behind that subject sharply in focus. This range of sharpness is called "Depth of Field" and varies with different lenses. With any lens you will find that Depth of Field is always greater at small lens apertures, such as  $f/16$ , and less at large apertures such as  $f/2$ .

Depth of Field is also greater with a more distant subject than a nearby subject and increases nearly twice

as much beyond the subject than in front of it.

To use the depth of field scale first focus on your subject then determine how great a Depth of Field a given aperture will give by reading distances against the two marks for that aperture. The figure on the left will be the nearest point in focus and that to the right the furthest, thus enabling you to select that aperture which will give the desired Depth of Field.

# Using the Meter



Over-exposure

Having focused on the subject set the Lens Aperture Ring [9] in the middle of the range (say f/8) and press the Shutter Release Button [3] about half-way. This will switch on the meter and one of two red lights on the right-hand side of the viewing frame will

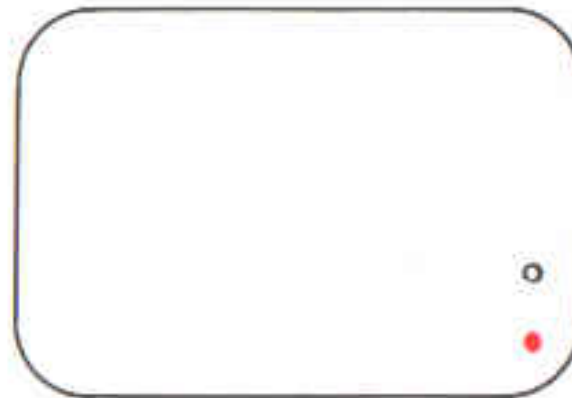

Under-exposure

come on. If it is the upper one this indicates over-exposure and the Aperture Ring [9] should be turned clockwise thus reducing the amount of light reaching the film. Should the lower light come on it indicates under-exposure and the Aperture Ring [9] should

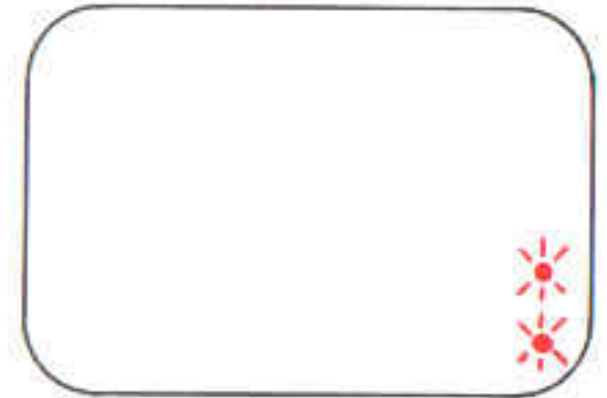

'Correct' exposure

be turned anti-clockwise. Turn until both lights flash rapidly in sequence – this is the correct exposure.

If it is not possible to get both lights flashing in sequence even at the end of the range of the Aperture Ring [9] then

alter the Shutter Speed Dial [1] up or down and repeat the process. The meter fitted in the Zenith 12 XP is very sensitive and in some cases the indicator lights may move from top to bottom without an intermediate 'flashing' stage. In this case choose the exposure at the point of the change from top to bottom when the latitude of modern film will still give you the correct exposure.

### **A Helpful Hint for Better Exposure**

The meter measures *all* the light reaching it and "averages" it to achieve a reading which is correct when dark and light areas are evenly balanced. When dark

and light areas are *not* evenly balanced (such as an illuminated face against a dark doorway or a person against a sun-lit background) then it will be necessary to take a close-up reading of the main subject – thus excluding the distracting area – and use this setting when you return to your original viewpoint.

# The Zenith 11

The Zenith 11 incorporates a built-in selenium exposure meter which needs no batteries. See pages 36/37 for operating controls. Apart from this it is identical to the Zenith 12 XP described throughout the rest of this booklet. Zenith 11 owners, therefore, should carefully study and follow all the instructions for the 12 XP apart from the meter.

**Set Film Speed.** In the cut-outs in the Aperture Indicator Dial [15a] there are two scales for films rated in ASA and DIN.

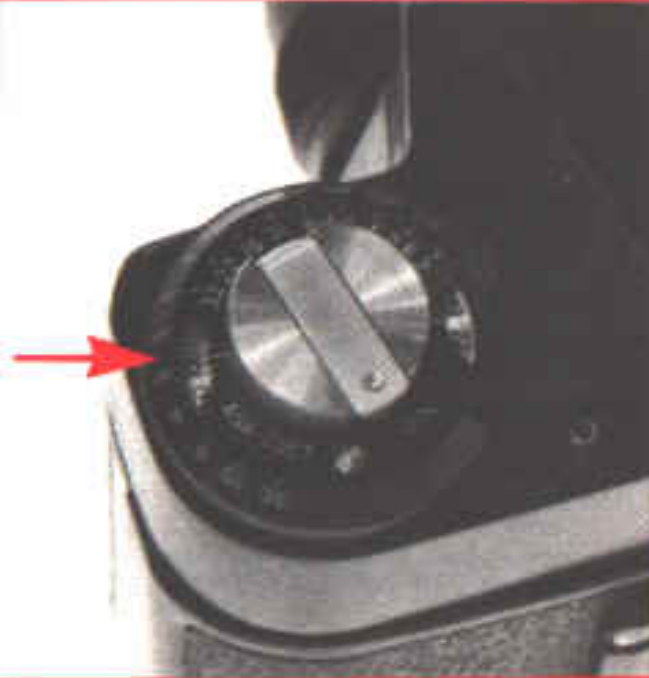

Set the speed of the film in use by turning the dial with the small projection. Any intermediate positions may be used and are proportionate.

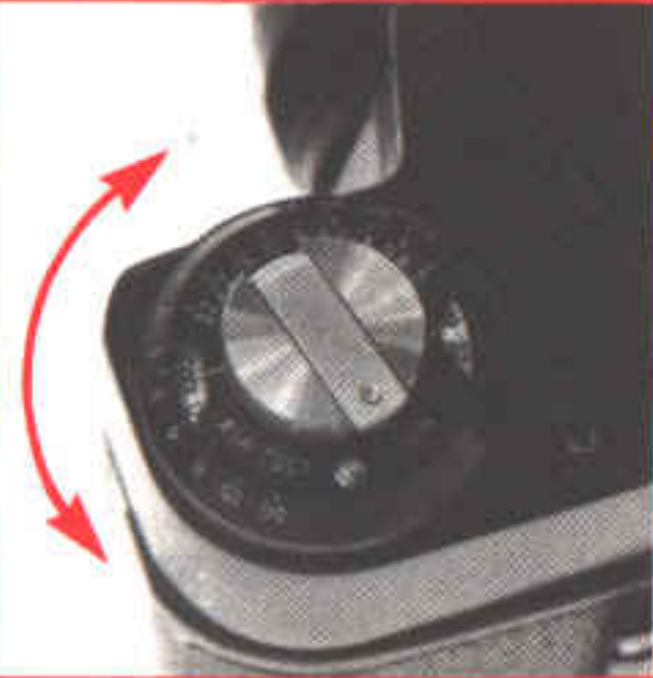

Point the camera at the subject, if outdoors with a bright sky tilt it downwards somewhat. Also study the 'Helpful Hint for Better Exposure' on page 14. Always ensure Exposure Meter Window [15c] is not obscured in any way when taking a reading.

With the camera still pointed at the subject turn the Shutter Speed Indicator Dial [15b] until the ring of the Exposure Meter Cursor [19b] is centred over the Exposure Meter Needle [19a]. Read off possible combinations of speed and aperture opposite each other on the two dials. Only those speeds in white may be set directly on the camera; of the others, 2-15 represent fractions of a second and are for information only but the figures 1-30 are whole seconds which may be used in a time exposure. Choose the most suitable combination.



Set the speed dial [17].



Set the Aperture Ring [9].

In extremely dim lighting, the Exposure Meter Needle [19a] may rest near the right-hand edge of the transparent window. Should this occur, place your hand close in front of the Exposure Meter Window and watch the needle carefully. If the needle moves when you block the meter cell the exposure meter is able to function in the existing light – remove your hand and determine exposure in the normal way. However, if no needle movement occurs when you place your hand in front of the meter cell the existing light is insufficient and the exposure meter cannot be used. In this event, either a time exposure or use of a flash gun is recommended.



## Removing Exposed Film – Step by step instructions



Replace the lens cap to prevent accidental exposure of film during rewinding.

Press Shutter Release Button [3].



With the finger tip depress the Film Rewind Sleeve (arrowed above) into the cut-out portion of the surrounding sleeve. It will click and stay down.

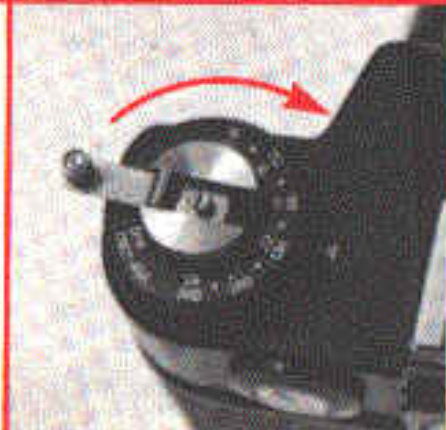

Lift out Rewind Crank [16] and rotate clockwise in the direction of the arrow. You will feel the film being rewound into the cassette – stop when resistance ceases.



Lift Rewind Knob [16] fully to open camera back. Remove exposed cassette.



Advance Film Transport Lever [2] in **short strokes** until it stops. The Film Rewind Sleeve will return to its original position.

Fire shutter.

The camera is now ready for your next film.

## Multi-Functions of Shutter Release Button

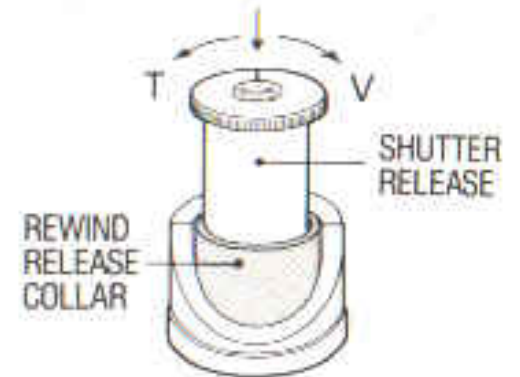

### For Film-Rewinding

In order to rewind film it is necessary to release the film drive. To do so fully depress the shutter release button and allow it to return to its normal position. Then depress the rewind release collar (see diagram) above) and follow instructions on page 17

**For Timed Exposures**  
see pages 21-22

**For Self-Timer**  
see pages 23-24

# Photography with Flash

The meter cannot be used when taking flash pictures as the burst of light is too short. In all cases the Speed Dial [1] **must** be set to "30-X", the aperture being determined by the camera-to-subject distance. Tables or calculators for this are given in the instructions for the flashgun often being incorporated into the gun itself. Some flashguns have built-in computers which allow the aperture to be left at one setting regardless of camera-to-subject distance.

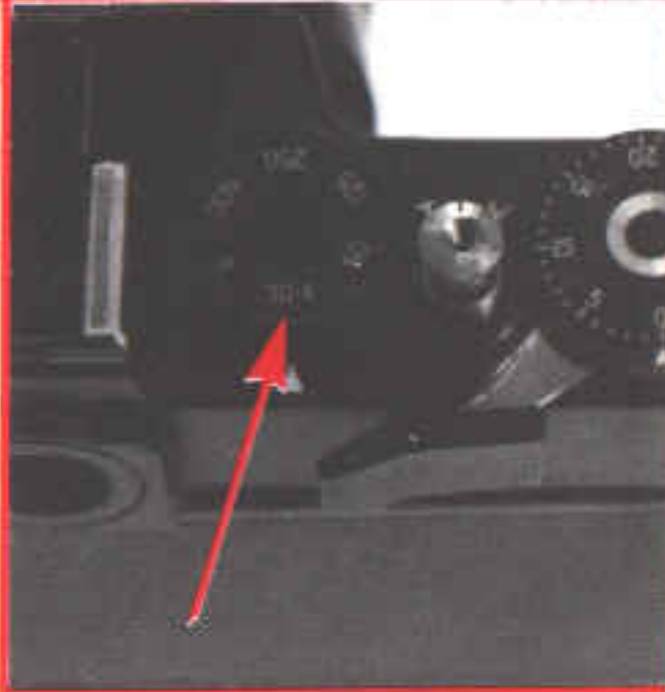

Set the Speed Dial to "30-X".

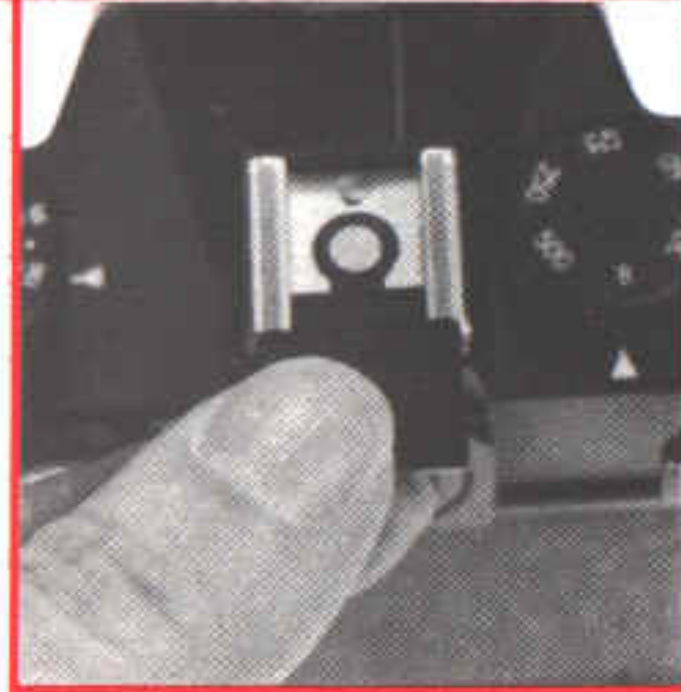

Remove square shield from Accessory Shoe [18] and put in a safe place.



A lightweight compact gun may be slid into the accessory shoe. If there is a lead connect the plug to Flash Sync. Socket [5].



A large or heavy gun must be fitted to a flash bracket screwed into one of the Tripod Bushes [23] on the camera base. Connect the lead to the Flash Sync. Socket [5].



Set Aperture Ring [9] in accordance with the flashgun's instructions.

Switch gun on, wait for "ready" light, focus and proceed.

Remember to replace the accessory shoe cover after removing gun.

# Time Exposures

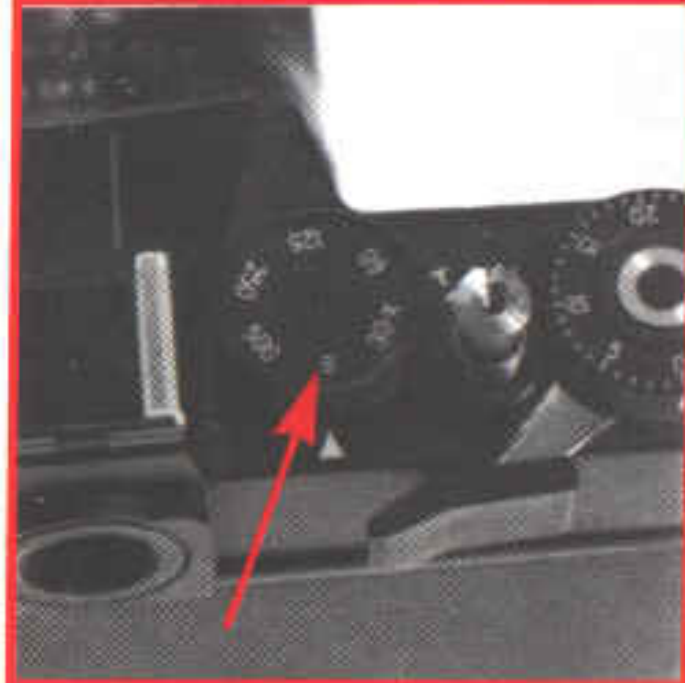

For exposures longer than the meter range (1/30th at f/2) the "B" setting on the Speed Dial [1] must be used. The exposure should be determined by using a hand-held meter such as the Leningrad or by experience/estimation.



Although the camera may be rested on a firm surface the best results will be obtained by the use of a tripod but avoid those of a flimsy nature. A **Helios** Tripod or **Helios** Mini-Tripod (illustrated) is ideal.



Set the Speed Dial to "B".

Set the Aperture Ring [9]. Focus and cock shutter by advancing Film Transport Lever [2] *in short strokes* until it stops.



Fit a short cable release (obtainable from any good dealer) into the screwed portion of the camera's Shutter Release Button [3]. Depress the cable release and the shutter will stay open until pressure is released. Some cable releases have a screw lock which avoids the need for holding it during a lengthy exposure.



If you do not have a cable release depress the camera's Shutter Release Button until the shutter opens and turn it fully anti-clockwise to the "T" position. The shutter will remain open until the button is returned to the normal position. We recommend the use of a cable release where possible as this will reduce the chance of

"camera shake" during the exposure.



**IMPORTANT** – Do not leave the Shutter Release locked in the 'T' position longer than necessary in order to minimise battery drain.

### Multi-Functions of Shutter Release Button

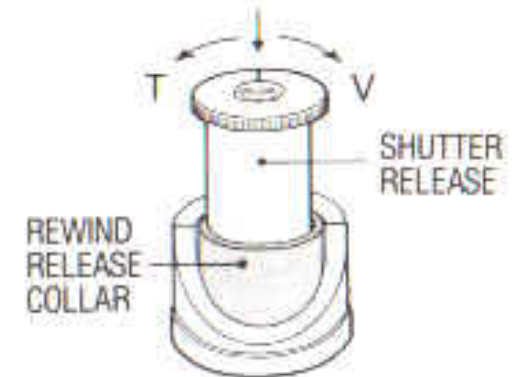

**For Timed Exposures**  
Follow instructions detailed left.

**For Film Rewinding**  
see pages 17-18

**For Self Timer**  
see pages 23-24

# The Self Timer

The Self Timer [7] provides about a seven second delay in the firing of the shutter and enables you to get into the picture yourself. Flash can be used.

Place camera preferably on a tripod, otherwise on a firm surface.

Set speed and aperture. Frame area in Viewfinder [27] and focus. Cock Shutter by advancing Film Transport Lever [2] in **short strokes** until it stops.



Depress Shutter Release button [3] half-way until lens closes down and turn it fully clockwise to the "V" position.



**IMPORTANT** – Do not leave the Shutter Release locked in the 'V' position longer than necessary in order to minimise battery drain.

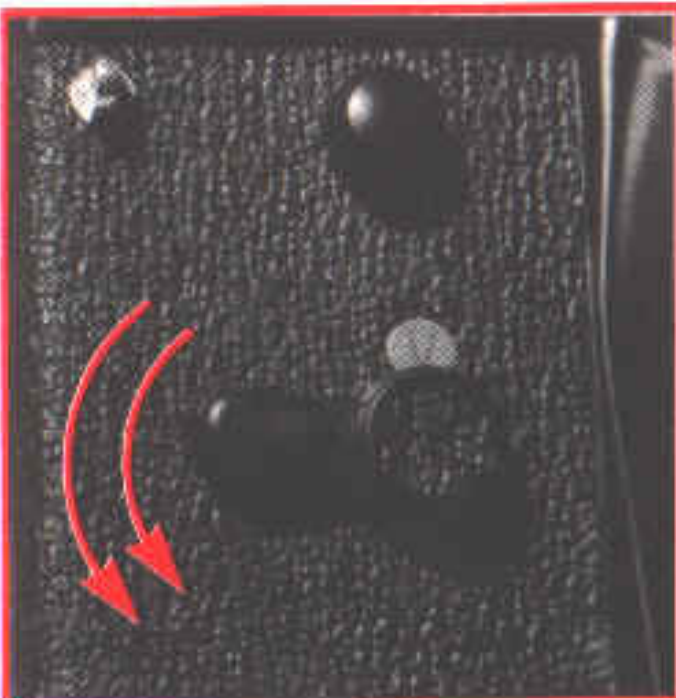

Turn the Self-Timer Lever [8] down until it will go no further. The "V" that is revealed is just a reminder that you should have set the Release Button [3] to its "V" position.

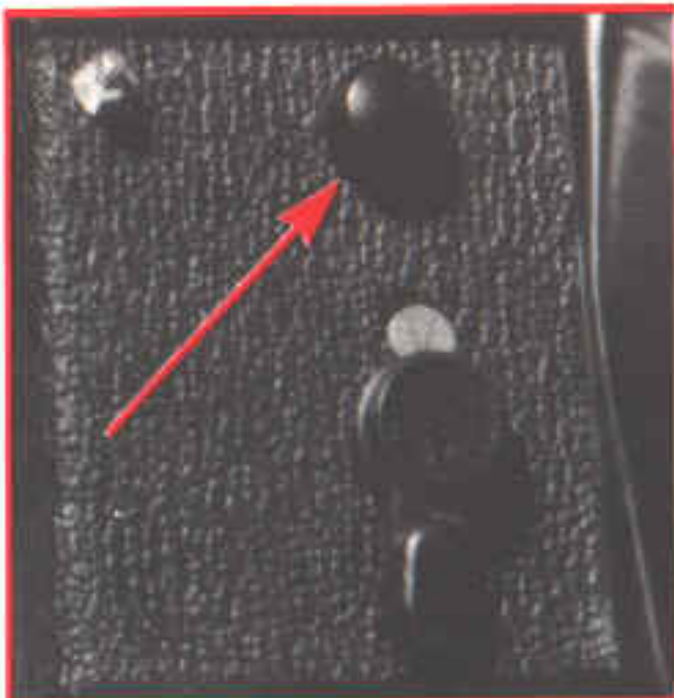

Press the Self-Timer Release Button [7] and move into the picture area as quickly as possible. The Lever [8] will slowly return firing the shutter during its travel.

## Multi-Functions of Shutter Release Button.

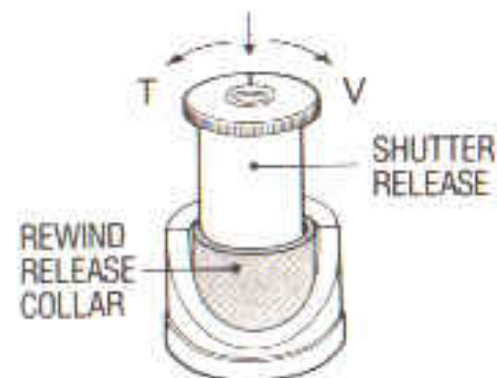

### For Self Timer

Follow instructions on page 23

**For Film Rewinding**  
see pages 17-18

**For Timed Exposure**  
see pages 21-22



# Changing the Batteries

The Meter is powered by two Mallory D386 cells which should be changed every twelve months.



**To remove.** Place coin in slot of Battery Cover [19] and turn anti-clockwise until slot is horizontal. Remove cover and old batteries.

Fit two new batteries both with "+" outwards. Replace battery cover with slot horizontal locating the two cover arms in the camera body slots. With a coin edge push inwards and turn to lock in vertical position.

Use a clean linen cloth when handling batteries – the grease from bare fingers can adversely affect the electrical contacts.

# Troubleshooting

If this happens . . .	Here is why . . .	And how to correct it . . .
After loading, Frame Counter [4] skips two or more numbers after being set to '0' position.	Film transport Lever [2] not fully wound before counter is set to '0' position.	Advance Transport Lever fully before setting counter to '0'.
Frame Counter [4] 'skips', counting incorrectly.	See above – or Counter set before Transport Lever was wound.	See above – always wind Transport Lever before setting counter.
Self-Timer does not trip shutter.	Self-Timer Lever [8] not fully wound. Transport lever [2] not wound.	Wind Self-Timer Lever fully until lever points downwards with no further movement possible. Always ensure Transport Lever is fully wound before setting Self-Timer Lever.
Film will not rewind.	Rewind release not engaged.	Refer back to page 17.
If anything should go wrong with your Zenith and the preceding chart has not got you out of trouble never attempt to mend it yourself – you could turn a minor adjustment into an expensive repair.		Remember that your Zenith and its accessories are backed up by top-class service facilities where factory-trained specialists are available to put things right.

# Zenith 11 Operating Controls

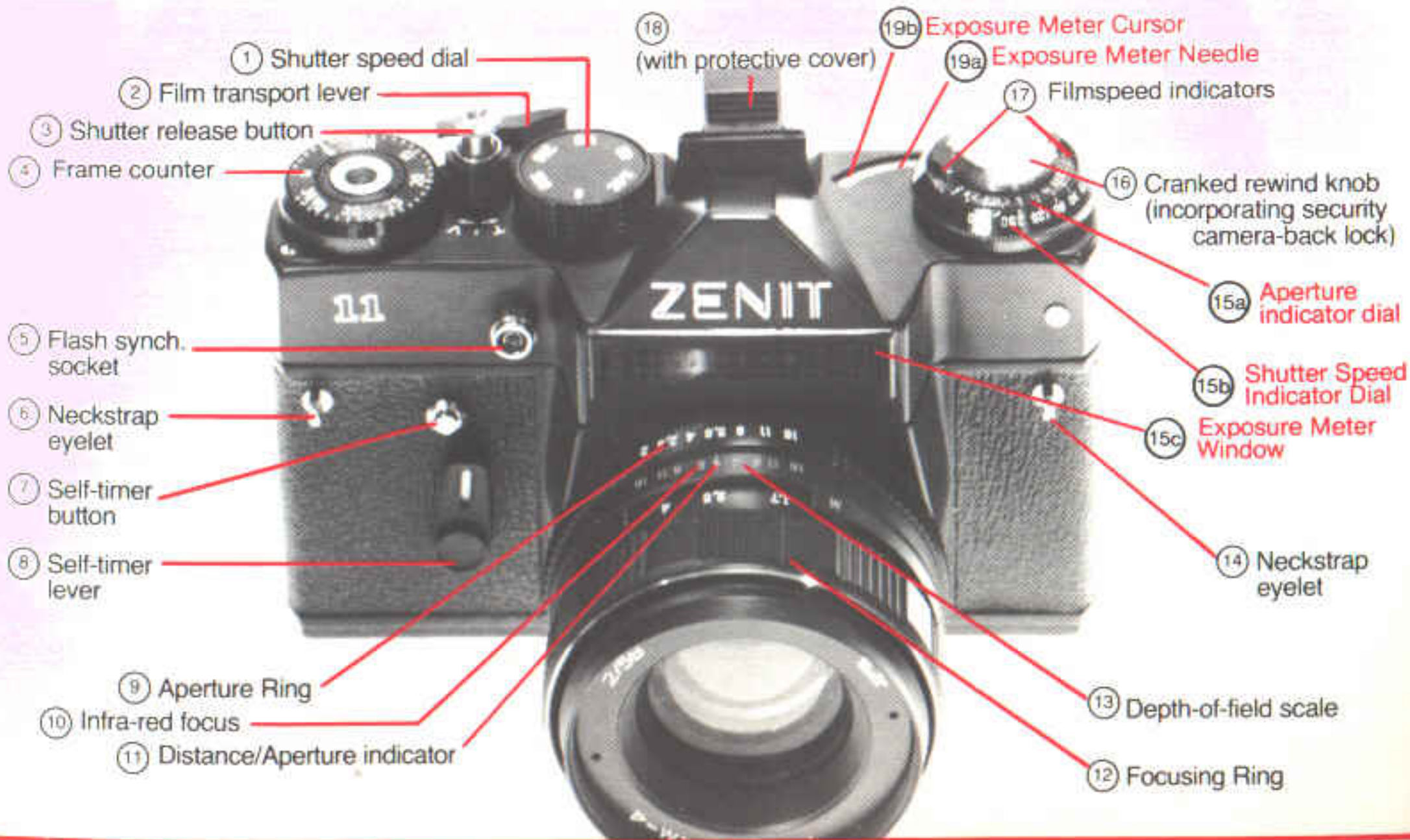

# Zenith 11 Operating Controls

